

Keysight Technologies

EMC Compliance Testing: Improve Throughput with Time Domain Scanning

Application Note

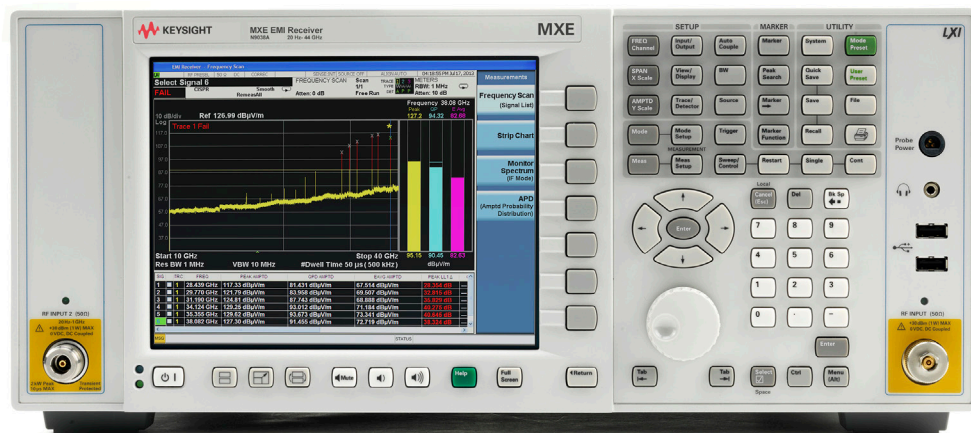

Introduction

Electromagnetic compatibility (EMC) testing requires detailed and exacting methodologies to ensure that all emissions are accurately measured. Long test times impact test facility availability and reduce the number of devices that can be certified—capping the amount of revenue a testing service can generate or the number of new devices a company with internal test capabilities can introduce without the cost of third party testing.

To grow revenue without adding the considerable expense of new test site installations, companies must streamline the EMC product test cycle—which includes setup, scan, turntable rotation, and antenna height adjustment time—to maximize the throughput of their existing compliance facilities. Time domain scan is a technology that can reduce receiver scan time significantly, shortening overall test time to help increase revenue and introduce more products to market faster.

This application note will provide you with an overview of time domain scan, discuss the test scenarios in which it provides the greatest time savings, and assess the trade-offs between time domain speed and receiver overload protection.

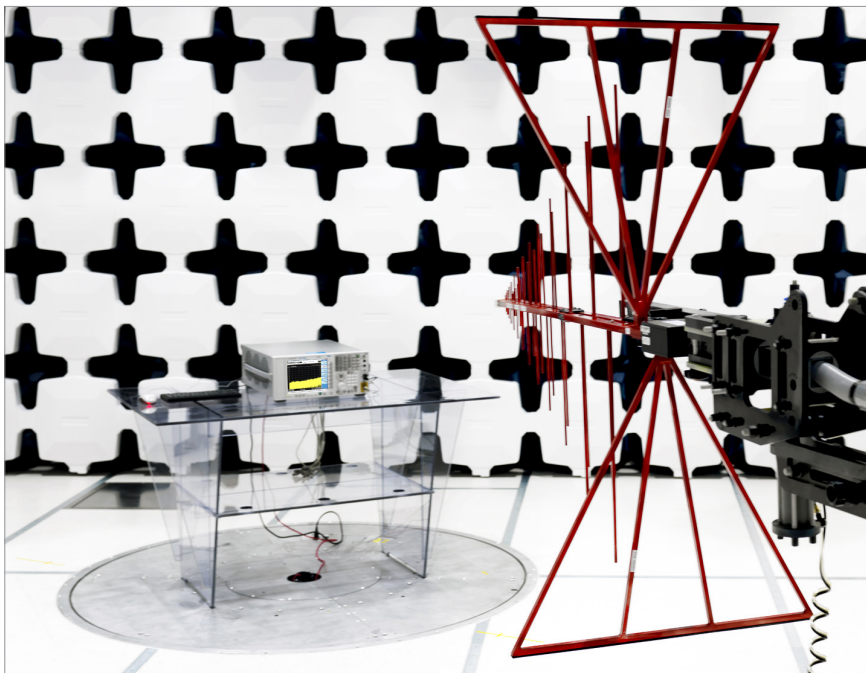

Time Domain Scan Reduces Overall Test Time

Both commercial and military testing standards require specific amounts of measurement time, also known as dwell time, for each signal in order to ensure that impulsive signals are appropriately characterized. Time domain scan reduces receiver scan time while maintaining required dwell times.

CISPR-based commercial testing can require dwell times up to 1 second for pre-scans and, in the case of emissions with time-varying amplitudes, 15 seconds or more for final measurements. MIL-STD-461 specifies dwell times of between 15 ms and 150 ms per measurement, depending on the frequency range. These dwell times add up when using receivers that employ frequency domain scanning based on stepped or swept local oscillators to collect data in individual resolution bandwidths.

Time domain scanning became acceptable for prescans in CISPR 16-1-1:2010 and is acceptable for final measurement in those CISPR standards specifically calling out the use of this version of CISPR 16-1-1. MIL-STD-461 allows the use of any type of measuring device that meets the requirements of the document.

How Time Domain Scan Works

Time domain scan reduces receiver scan time through the use of high-overlap fast Fourier transforms (FFT) to collect emissions data simultaneously over a frequency span that includes multiple resolution bandwidths (Figure 1). By contrast, in the frequency domain, data is collected in individual resolution bandwidths. The FFT acquisition bandwidths used for time domain scan can be in the range of 1 to 10 MHz or greater, significantly wider than the required CISPR and MIL resolution bandwidths. The receiver collects the data in the wider acquisition bandwidth and processes it into the appropriate regulatory bandwidths to ensure that the measurements meet regulatory requirements. Time domain scan saves measurement time because the appropriate regulatory dwell time is applied only once for all data in a given FFT acquisition bandwidth, in comparison to frequency domain scanning which requires that the receiver dwell for each measurement made.

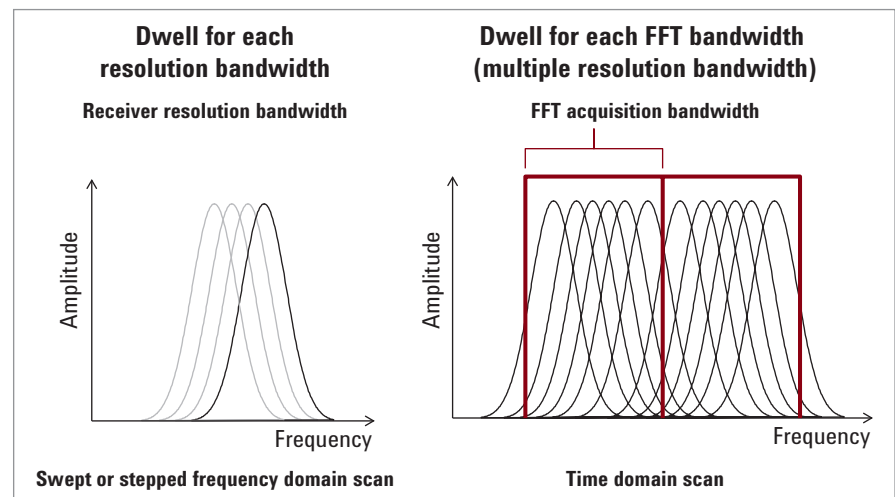

Figure 1. Comparison of resolution and FFT acquisition bandwidths

An additional time savings is achieved with time domain scan because the wider acquisition bandwidths require fewer frequency steps, compared to stepped frequency domain scanning, to cover an entire band of interest. Each frequency step requires the local oscillator to change frequencies—the fewer the number of steps, the lower the total LO relock time.

Time domain scan measurements must comply with CISPR 16-1-1:2010 and MIL-STD-461 amplitude accuracy requirements. In order to achieve the required amplitude accuracy, designers use a very high level of overlap (~ 90%) when calculating the FFTs. In addition, the EMI receiver must maintain a high level of amplitude distortion performance over the wider IF acquisition bandwidths.

The high degree of FFT overlap in the time domain ensures that impulsive signals are captured and measured accurately. Figure 2a displays an impulsive signal in the time domain when using contiguous or low-overlapped FFTs. If an input signal occurs outside of an FFT period, the reported signal amplitude could be low or completely missing. Figure 2b displays the same signal in the time domain when using highly-overlapped FFTs. In this situation, there is a much higher probability of capturing the signal and reporting the correct peak amplitude.

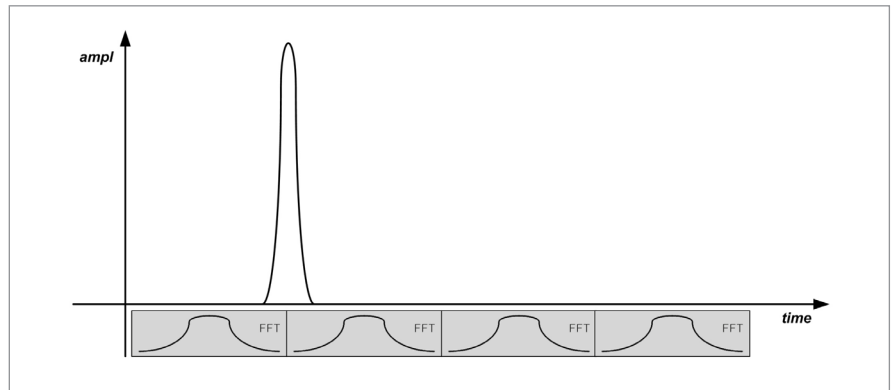

Figure 2a. Traditional critically-sampled FFTs with contiguous windows has potential for missing input impulsive signal

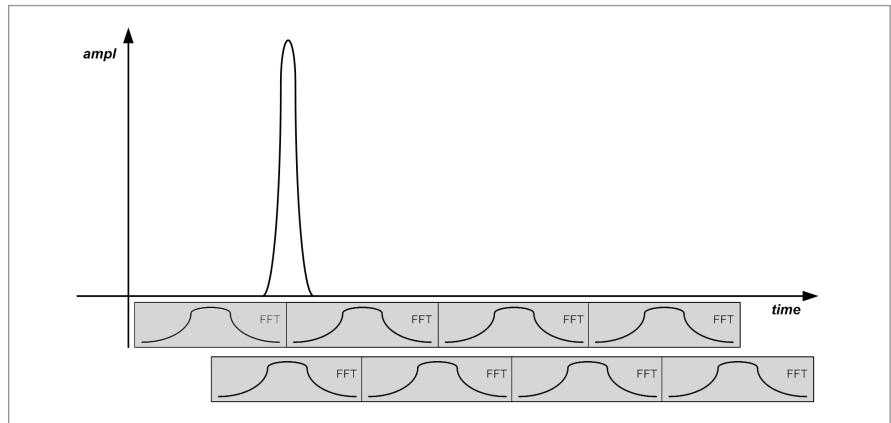

Figure 2b. Measurements made with FFTs highly overlapped in the time domain increase probability of intercept and minimize amplitude measurement scalloping

Time domain scan acquisition bandwidths must also take RF and microwave preselector bandwidths into account. Preselector filters band-limit the RF energy that can reach the receiver's first mixer, improving available dynamic range when measuring impulsive signals. Two ways in which time domain scan accounts for preselector filters to ensure FFT amplitude accuracy are by:

- Adjusting the amplitude vs. frequency response across the FFT acquisition bandwidth to compensate for the preselector edge-of-band response
- Reducing the maximum FFT acquisition bandwidth so that FFT amplitude vs. frequency effects do not significantly add to preselector amplitude vs. frequency response

Reduce Prescan from Hours to Minutes

The main elements of compliance testing that require test facility time (the capacity-limiting resource) are:

- Equipment under test (EUT) setup and tear-down
- Prescan to identify suspect frequencies, including antenna and turntable movement and receiver scanning times
- Final measurement, including antenna and turntable movement times and single-frequency receiver measurement times

Report generation is not included in this list because this work can be done in a location other than the test facility.

Setup and tear-down times vary greatly with EUT type and can range from less than one hour to a significant portion of a day, or longer. Antenna movement time varies with manufacturer, but typically is ~5 seconds for each antenna position. Turntable movement time also varies with manufacturer, but typically is in the range of 1-2 RPM. For this discussion, we'll assume ~5 seconds for each 15 degree rotation. Final measurement time can vary broadly, depending on the number of frequencies in the suspect list and the amount of required dwell time at each frequency.

Time domain scanning provides significant time savings during pre-scan (the collection of suspect signals prior to final measurement) because it is during this process where the receiver tunes through the entire measurement band. For example, when collecting suspect frequencies according to methodologies required in CISPR 16-2-3: 2010, ed. 3.1, section 7.6.6, a sweep should be made for every 15 degrees of turntable rotation and for both polarizations of the receive antenna (total of 48 receiver scans). In addition, antenna height scanning may be required. For this discussion, we will say that measurements for 3 heights will be made at each azimuth for each polarization, for a total of 144 receiver scans.

To measure emissions in the 30 MHz to 1 GHz range, the suspect list is created by prescanning with a peak detector, 4 measurement points for every resolution bandwidth (in this example, every 30 kHz for a 120 kHz CISPR resolution bandwidth), and a 10 ms dwell time for each point. In the frequency domain, commercially available receivers make this scan in approximately 250 seconds, which would result in a total prescan scanning time of approximately 10 hours!

For example, using time domain scan, the N9038A MXE EMI receiver can make this same scan in about 12 seconds, reducing the total scan time to just under 30 minutes—a significant time savings. Note that in both scenarios, the total associated turntable and antenna movement time required to collect these 144 scans is approximately 12 minutes.

Time Domain Prescans Don't Replace Final Measurements

Time domain scanning can also be used to reduce scan times when using the CISPR-specified weighted detectors (quasi-peak, EMI-avg, and RMS-avg detectors). While the weighted charge and discharge times associated with these detectors still result in time domain scans that are slower than scans taken with a peak detector, these weighted time domain scans are significantly faster than weighted frequency domain scans.

This weighted detector scan time reduction has led some in the industry to suggest that test facilities can achieve additional test time savings by using fast time domain weighted detector prescan results in place of a final measurement. The weighted detector prescan amplitude is used to evaluate whether the suspect meets the emissions limit, rather than the final measurement amplitude.

Unfortunately, this technique does not align with CISPR-recommended measurement methodology. CISPR 16-2-3:2010 ed. 3.1, section 6.5, requires that the weighted amplitude of each final signal be monitored to ensure that it is steady. If not steady, CISPR requires that the amplitude-variation of the signal be monitored for 15 seconds. If the variation over that 15 second period is greater than 2 dB, the signal would need to be monitored for a longer period. In order to use weighted detector time domain scan values to screen an emission to a limit line in accordance with CISPR requirements, the user would have to dwell for a longer period of time—15 seconds or more—to ensure that they have captured the maximum value of all signals in the scan. This increase in dwell time negates any test time savings with this method.

Preselector Considerations: Speed vs Overload Protection

Receiver design can improve time domain speed with wider acquisition bandwidths, collecting more measurement bandwidths in each acquisition. In order to take advantage of wider acquisition bandwidths, the receiver preselector filter bandwidths must also widen. However, widening the preselector bandwidths further reduces the available impulse measurement dynamic range, lowering the impulsive overload threshold.

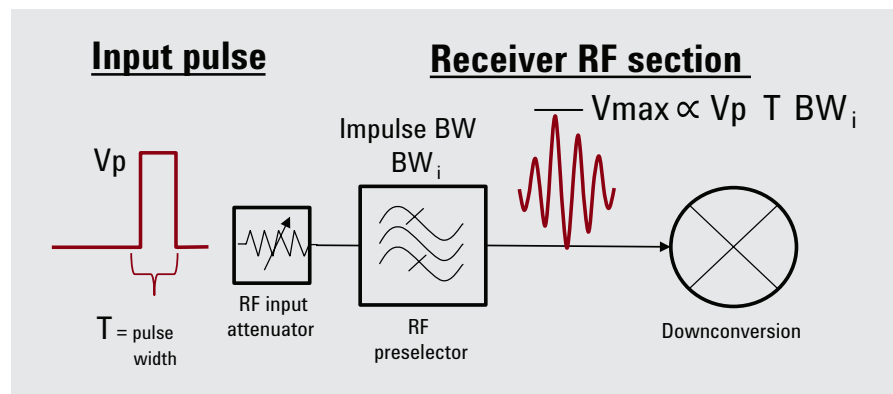

Figure 3. Preselector impulse bandwidth limits impulse input voltage to receiver downconversion chain

The purpose of RF and microwave preselector filters is to reduce impulsive broadband energy to the first mixer, improving overload levels and measurement dynamic range when measuring impulsive signals (Figure 3). For a given impulse, the maximum signal level passing through the filter is proportional to the amplitude of the pulse (V), the duration of the pulse (T), and the impulse bandwidth (BW_i) of the filter.

$$V_{in\ max} \propto VT\ BW_i$$

Widening a preselector filter to increase time domain scan speed increases the filter impulse bandwidth and effectively reduces the receiver overload level for impulsive signals. The overload protection can be recovered using additional input attenuation, but at the expense of measurement sensitivity. Given that sensitivity is a key parameter for EMC testing, system designers need to consider whether they are willing to trade sensitivity for additional measurement speed and if the net time savings realized compared to the total measurement time (including setup and tower/turntable adjustment time) is worthwhile. In many cases, the savings is only a small percentage of the total measurement time and may not warrant the sensitivity reduction.

When evaluating a receiver for your test facility, it is important to understand the tradeoffs between time domain scan speed and overload protection. An effective method to determine relative overload protection for receivers with comparable distortion specifications—1 dB compression and third-order intercept (TOI) specifications are the most critical—is to compare the ratio of the preselector 6 dB filter bandwidths at a given frequency.

By calculating:

$$20\log \left[\left(\text{wider BW}_{6\text{dB}} \right) / \text{narrower BW}_{6\text{dB}} \right]$$

system designers can get a reasonable estimate of the additional input attenuation that would be required by the receiver with the wider preselector bandwidth to avoid overload when measuring large impulsive signals.

Selecting the Right Receiver for Time Domain Scans

Time domain scanning speed is dependent on receiver architecture. While faster speeds can be achieved using wider acquisition bandwidths, the wider preselector bandwidths reduce the receiver's impulsive dynamic range by allowing more impulsive input energy into the downconversion chain. This reduction in overload level can be accounted for by using additional input attenuation, but the tradeoff is loss of measurement sensitivity.

The N9038A MXE EMI receiver offers both excellent overload protection and fast time domain scanning, making it an excellent choice for any compliance test facility. It provides a very high degree of impulse overload protection through the use of narrow RF preselection filters. Sixteen filters (11 fixed, 5 tunable) cover the 20 Hz to 1 GHz range, with bandwidths ranging from 300 kHz to 60 MHz. Above 3.6 GHz, a YIG preselector filter is used to provide ~60 MHz of preselector filtering.



Summary

Time domain scanning can significantly improve EMC test lab throughput by reducing overall measurement test time. This time savings can translate into additional revenue and new product introductions for test facilities that are capacity constrained. While test time savings vary with measurement requirements, time domain scan can reduce testing to commercial standards by several hours. Time domain scanning provides the greatest benefit for testing methodologies that require turntable rotation and antenna height variation during prescan while identifying a list of suspect frequencies for final measurement.

myKeysight

myKeysight

www.keysight.com/find/mykeysight

A personalized view into the information most relevant to you.



www.axiestandard.org

AdvancedTCA® Extensions for Instrumentation and Test (AXIe) is an open standard that extends the AdvancedTCA for general purpose and semiconductor test. Keysight is a founding member of the AXIe consortium. ATCA®, AdvancedTCA®, and the ATCA logo are registered US trademarks of the PCI Industrial Computer Manufacturers Group.



www.lxistandard.org

LAN eXtensions for Instruments puts the power of Ethernet and the Web inside your test systems. Keysight is a founding member of the LXI consortium.



www.pxisa.org

PCI eXtensions for Instrumentation (PXI) modular instrumentation delivers a rugged, PC-based high-performance measurement and automation system.



Three-Year Warranty

www.keysight.com/find/ThreeYearWarranty

Keysight's commitment to superior product quality and lower total cost of ownership. The only test and measurement company with three-year warranty standard on all instruments, worldwide.



Keysight Assurance Plans

www.keysight.com/find/AssurancePlans

Up to five years of protection and no budgetary surprises to ensure your instruments are operating to specification so you can rely on accurate measurements.



www.keysight.com/go/quality

Keysight Technologies, Inc.
DEKRA Certified ISO 9001:2008
Quality Management System

Keysight Channel Partners

www.keysight.com/find/channelpartners

Get the best of both worlds: Keysight's measurement expertise and product breadth, combined with channel partner convenience.

For more information on Keysight Technologies' products, applications or services, please contact your local Keysight office. The complete list is available at: www.keysight.com/find/contactus

Americas

Canada	(877) 894 4414
Brazil	55 11 3351 7010
Mexico	001 800 254 2440
United States	(800) 829 4444

Asia Pacific

Australia	1 800 629 485
China	800 810 0189
Hong Kong	800 938 693
India	1 800 112 929
Japan	0120 (421) 345
Korea	080 769 0800
Malaysia	1 800 888 848
Singapore	1 800 375 8100
Taiwan	0800 047 866
Other AP Countries	(65) 6375 8100

Europe & Middle East

Austria	0800 001122
Belgium	0800 58580
Finland	0800 523252
France	0805 980333
Germany	0800 6270999
Ireland	1800 832700
Israel	1 809 343051
Italy	800 599100
Luxembourg	+32 800 58580
Netherlands	0800 0233200
Russia	8800 5009286
Spain	800 000154
Sweden	0200 882255
Switzerland	0800 805353
	Opt. 1 (DE)
	Opt. 2 (FR)
	Opt. 3 (IT)
United Kingdom	0800 0260637

For other unlisted countries:
www.keysight.com/find/contactus
(BP-09-23-14)

